

VHF B.I 2-Way Quadrature Splitter

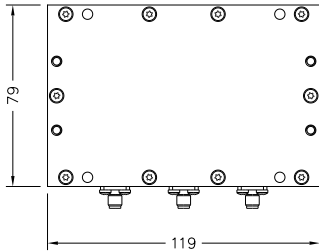
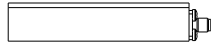
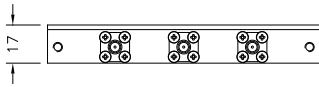
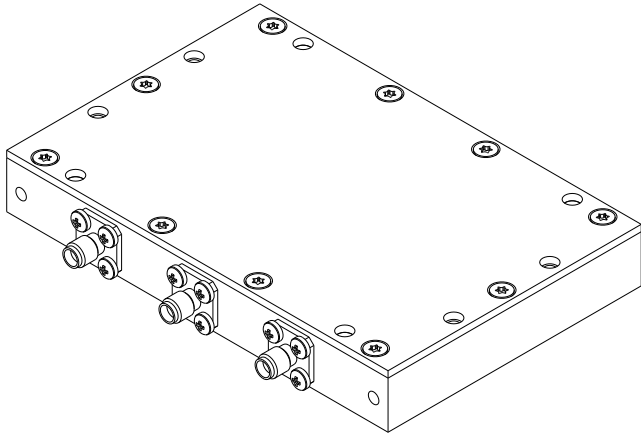

FEATURES

- Quadrature Power-Combination
- Flat Frequency Response
- Matched Multicouplers: MC-Series
- 10-Year Warranty

SPECIFICATIONS

Code / Revision	C-QS2A / A
Matched Multicoupler	-
Frequency Range	54-108 MHz
Max RMS Input Power ⁽³⁾	10.0 W
Insertion Loss	< 4.2 dB
Return Loss (VSWR)	> 22 dB (1.17)
Isolation	> 22 dB
Amplitude Balance	< ±0.1 dB
Phase Deviation	< ±3°
Max Operating Temperature (Body)	65 °C (149 °F)
Environmental Conditions	-5 to +55 °C (+23 to +131 °F), IP60
Dimensions / Weight ⁽¹⁾	119x79x17 mm / 0.3 kg
Connectors ⁽⁸⁾	1x 12 mm Input D-PC12A SMA Female (Default) D-PC12C N Female 2x 12 mm Outputs D-PC12A SMA Female (Default) D-PC12C N Female

⁽¹⁾ Approximate, default configuration ⁽³⁾ Altitude < 1500 m (4.900 ft.), Free air, Ambient temp. <30 °C (86 °F) ⁽⁸⁾ Other Connections available

