

UHF 1 kW 6/7-Pole Balanced Combiner

DB6X30C
DB7X30C

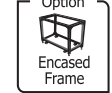

TRANSMITTING COMBINERS
UHF

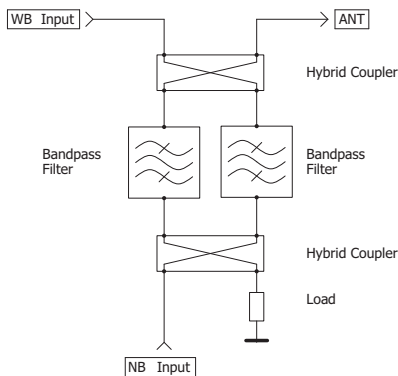
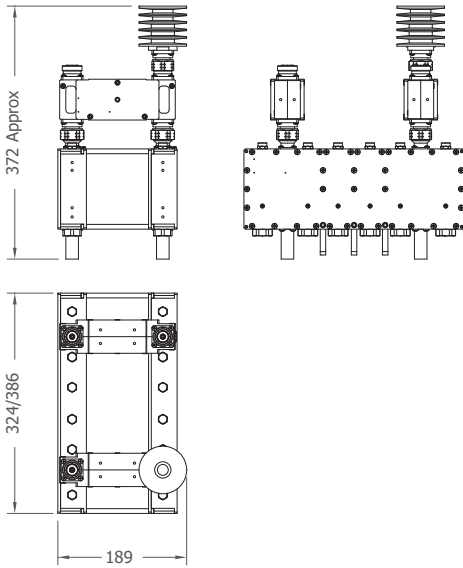

SPECIFICATIONS

	DB6X30C	DB7X30C
Product Code	B-DB6X30C-xxx-yy	B-DB7X30C-xxx-yy
DVB Mask	Non Critical Mask	Critical Mask
ATSC Mask	Simple Mask	Stringent M.
ISDB Mask	Non Critical Mask	Critical Mask
Frequency Range	470 – 862 MHz	
Bandwidth	6 to 8 MHz	
Order	6-Pole EIL. Resp.	7-Pole EIL. Resp.
Max NB Input Power	200 W DTV (300 W ATV)	
Max Output Power	1 kW DTV (1.5 kW ATV)	
Temperature Stability	< 2 kHz / K	
Max Operating Temp.	70 °C (158 °F)	
Environmental Conditions	-5 to +55 °C (+23 to +131 °F), IP60	
Body Finish	Metallic black coloring	
Dimensions	189 x 324 x 372 mm	189 x 386 x 372 mm
Weight	7.5 kg (16.5 lb)	8.5 kg (18.5 lb)
Part List	2 x CL6X30C 2 x HC40C 1 x DH30C	2 x CL7X30C 2 x HC40C 1 x DH30C
Links	7-16 3U Matching Bridge Link	
Frame	Encased Frame (N≥2)	
Connectors Interface	3 x 32mm Series	
Connectors	D-PC32C N Female D-PC32E 7-16 Female (Default) D-PC32G EIA 7/8" Socket D-PC32H EIA 7/8" Flange	
Options	O-LM.01 EIA 7/8" M.L. section O-RK.04 3U 19" Rack, w/ handles O-FE.01 Encased Frame (N=1)	

TUNING DATA*

	DVB 8 MHz N.C.M. (DB6X30C)	DVB 8 MHz C.M. (DB7X30C)	ATSC Simple M. (DB6X30C)
NB Insertion Loss	< 1.00 +0.05-N dB @ C.F. < 2.70 +0.05-N dB @ C.F. ±3.8 MHz	< 1.40 +0.05-N dB @ C.F. < 4.80 +0.05-N dB @ C.F. ±3.8 MHz	< 1.20 +0.05-N dB @ C.F. < 2.20 +0.05-N dB @ C.F. ±2.7 MHz
WB Insertion Loss	< 0.05-N dB	< 0.05-N dB	< 0.05-N dB
Selectivity	> 5 dB @ C.F. ±4.2 MHz > 16 dB @ C.F. ± 6 MHz > 41 dB @ C.F. ± 12 MHz	> 15 dB @ C.F. ±4.2 MHz > 26 dB @ C.F. ± 6 MHz > 51 dB @ C.F. ± 12 MHz	> 10 dB @ C.F. ±3.5 MHz > 24 dB @ C.F. ± 6 MHz > 36 dB @ C.F. ± 9 MHz
Return Loss**	> 26 - 6·log N dB (VSWR < 1.11 + 0.12·log N)	> 26 - 6·log N dB (VSWR < 1.11 + 0.12·log N)	> 26 - 6·log N dB (VSWR < 1.11 + 0.12·log N)
De-coupling	> 30 dB	> 30 dB	> 30 dB
NB Group Delay Variation	< 200 ns	< 320 ns	< 150 ns
Over-Temperature	< 23 K @ 200 W DTV	< 26 K @ 200 W DTV	< 26 K @ 200 W DTV

*Non Adjacent Channels ** WB: one channel optimization